

The Four Elements of Santorini Architecture

Lessons in Vernacular Sustainability

Thanos N. Stasinopoulos

School of Architecture, NTUAthens, Greece
tns@oikotekton.net

ABSTRACT: The vernacular architecture of Santorini is a splendid example of a built space skilfully adapted to a harsh natural setting. This paper introduces its features through a systematic approach based on the 'Four Elements' concept (fire, water, earth, air) that according to ancient philosophy are the origins of nature. Each element is associated with the local environmental attributes like solar radiation, humidity, materials, wind etc., that have been fused by the ingenuity of local generations (a 'Fifth Element'?) into a minimalist as much as intricate architectural idiom of highly sustainable quality -until the era of mass tourism.

Keywords: vernacular, sustainability, Santorini, Greece

1 Introduction

1.1 The four elements concept

According to a long line of scholars, from the ancient Greek philosophers to the medieval alchemists, the very essence of nature are four key elements in various configurations & interactions:

- ☉ *Fire* (e.g. the sunlight or volcanoes)
- ⊕ *Earth* (e.g. the soil and most materials)
- *Air* (e.g. the wind or oxygen)
- ⊖ *Water* (e.g. the sea or rain)

An obscure fifth element ('ether'?) of rather spiritual nature is thought to bind the other four together, being the catalyst of life.

Greek philosophers linked these elements to the five Platonic solids, and Aristotle related the four main elements to our senses as shown below, with additional reference to the four seasons.



The philosophical aspects of the four elements are not the issue here; instead, it is their utilization as a systematic tool to look at architecture in relation to nature.

The vernacular settlements of Santorini are an excellent case to demonstrate that approach, as they offer numerous features at various scales that manifest the connection between the built environment and the four elements, exemplifying the influence of the natural forces in shaping architecture. From minute building details to entire neighbourhoods, from man-made structures to natural formations, Santorini seen through the 'four elements prism' highlights not only the power of nature but also the traditional response to natural conditions -and perhaps the effects of the contemporary lack of it.

1.2 The island of Santorini



Fig. 1: Santorini houses: seagulls on the cliffs.

Santorini or Thira is a striking natural example of the interaction between the four elements: it is a group of islands around the bay of 'Caldera', 90 km north of Crete, remnants of a gigantic volcanic eruption (ca. 1500 BC) that obliterated the Minoan society of Crete with colossal tidal waves and a cataclysm of ash.

Several scholars believe that Santorini was the legendary Atlantis that vanished due to a sudden natural disaster as described by Plato. Recent excavations revealed a large settlement about 35 centuries old, well-preserved under thick volcanic ash layers, which many believe is a trace of the famous lost civilisation.

The landscape still bears clear marks of the great eruption: towards the crater there are steep red & black rock cliffs up to 300m high covered with light-coloured ash and pumice, and on the outer side there are smooth hills and long beaches with dark sand. The volcano remains active as indicated by the sulphur-coloured warm water surfacing at the middle of Caldera bay which is almost 400 m deep.

1.3 Santorini climate

Climatic conditions are typical of south Aegean region, with long sunshine and low precipitation. Humidity is fairly high even in summer due to the sea-water mass, and for the same reason seasonal temperature fluctuations are rather limited generating mild winters and summers. Winds usually come from the north quite strongly -especially in winter- although the ones from the south can be fairly severe too. Despite the widespread perception about the Greek islands, Santorini climate is rather cool during several months, when comfort conditions can be improved by the intense solar radiation -but also worsened by the forceful winds.

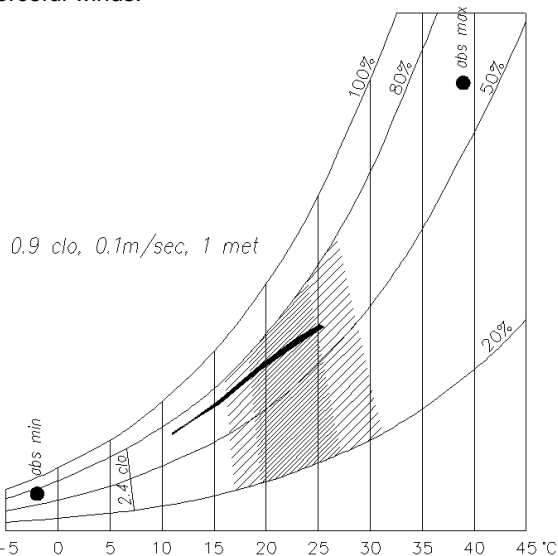

Fig. 2. Mean ambient temperature & humidity in Santorini lie within the comfort zone for most of the year, but with a substantial period on the cold side.



Fig. 3: An avalanche of whitewashed plaster.

2 Santorini architecture

2.1 The built fabric

The old settlements of Santorini, like in most small Aegean islands, are placed far from the shore: the fear of pirate assaults forced the locals to settle on steep cliffs or hidden valleys that offered better defence or were harder to spot from the sea. High density, narrow streets and small buildings have resulted from many factors: shortage of safe land, mutual

protection from the wind and solar heat, security, family growth, saving of construction materials, as well as the highly communal spirit of the old societies. In similar cases like Mykonos or Astypalea, densities of up to one person per square meter have been reported, so we can imagine cramped conditions in Santorini too -without counting the numerous domestic animals, from chicken to donkeys.

Oia, a village of predominantly naval population at the NW end of Santorini, features a layout clearly reflecting a hierarchical society: ship crews were living in cramped dwellings stacked on the steep cliff, whilst rich captains' mansions occupy comfortable space on the flat top with far better daylight and ventilation conditions; both classes were at a 'safe' distance from the farmers of nearby village of Finikia.

2.2 Major building features

The buildings of Santorini resample those in the rest of Cycladic islands: solid volumes, thick masonry walls with small openings, the whitewashed plaster skin covering almost everything with an integrative power, the creation of composition through continuous repetition. All those elements have produced organic urban & building forms, evolving through a long response to the climatic conditions using the locally available resources, and at the same time imprinting the social evolution through time.

A particular ergonomic scale is evident, similar to the one found in ships: low doors, narrow and steep stairs, tiny inner/outer spaces. These are products of necessity rather than choice, since the dominant design rule was material and space *minimalism*.

Nature is the chief designer of that architectural idiom, imposing its whims on the local builders, i.e. the dwellers themselves in most cases. Climate, earthquakes, materials scarcity, and topography had been the primary design parameters, and were respected with admirable integrity & ingenuity. Tradition resulting from long experience was dictating the building specifications from layout to decoration, with little ground for experiments or deviations from the established norms.

In such context, the introduction of neoclassical elements at the end of the 19th century must have been a radical act, adopted by rich captains who could afford showing off that they follow the new architectural style that was then flourishing in Europe.



Fig. 4: A *mélange* of roofs, walls, terraces and stairs.

3 The four elements

3.1 Earth

Building materials

The main building material is the plentiful red or black lava stone, used with or without mortar and covered with plaster that protects the joints from the decay caused by wind and rain, offering also a clearly visible clue for cracks.

Although surrounded by the sea, Santorini is a very dry, wind-swept volcanic land hostile to vegetation, especially trees. As a result, timber had been a costly luxury, brought from distant places and over steep cliffs, which the locals used to construct items like boats, furniture or doors rather than building elements like roofs, lintels, or wall ties.

The volcano has offered a compensation for the lack of structural timber: 'Theran soil', a volcanic ash with properties very similar to cement, had been widely used from ancient times to make mortar that was very strong, easily available and cheap.

Vaults

Given the scarcity of timber and the abundance of Theran soil, it is no wonder that the locals developed an architecture based on the compression strength of stone: the most common way to span large or small spaces was through quite thin vaulted roofs, bridging the gap between the much thicker sidewalls that withstand the horizontal forces of the vault.

That type of construction was so easy that it was applied even in very small scale. Today it has become the 'trade-mark' of Santorini, with many concrete replicas in spite of their higher cost than the original version.

Thin vaults offer little protection against solar heat coming from high altitude in summer, or radiant losses to the clear night sky in winter; therefore they were often covered by a layer of pumice –another product of the volcano- enclosed in parapets that converted the curved top into a flat roof.

That transformation made rainwater collection easier than the symmetrical vaults. Moreover it was a way to show off wealth, since vaults were regarded as a too common and less 'classy' structure than timber flat roofs. For instance, the elaborate cross vault ceilings of rich mansions are visible only from inside, as they have been hidden under 'flat' roofs.

As an extra sign of wealth, the upper half of the facades of those prominent buildings is often ornamented with exposed red masonry, which in less lavish houses is used only to outline openings. In less prestigious examples, the vaults are hidden behind free standing rectangular parapets or even triangular gables adding a 'neoclassical' flavour.

Volcano & earthquakes

A key feature of old masonry buildings in Santorini is their resistance to earthquakes: the volcano reminds its presence with frequent tremors, and traces of past calamities like that of 1956 are still around. Aseismic rules shaped the overall geometry of the building, as well as of many details in plan and elevation, like thick side walls and thin vaults, buttresses and tendons, narrow openings and rigid corners.

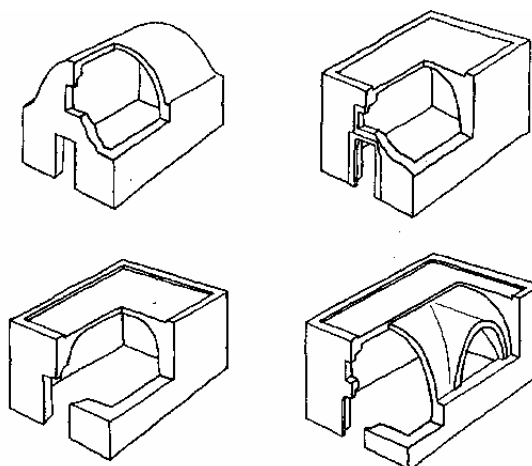

Fig. 5: Variations of vaults and cross-vaults.

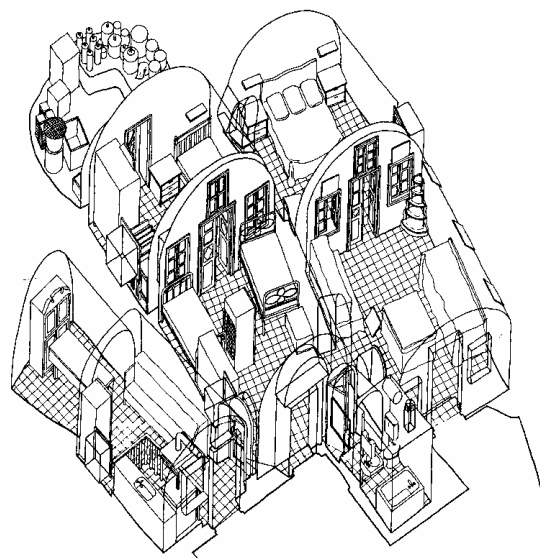

Fig. 6: Excavated houses are often separated into 2 or 3 rooms with narrow facades on a common yard.

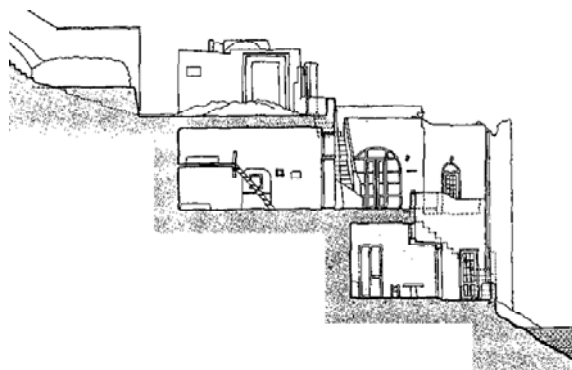

Fig. 7: Excavated and built dwellings were stacked on the steep ground in a 3D layout.

Excavated shelters

Santorini is one of the few places in Europe with troglodytes even today: the special properties of the ground, coupled with the necessity of materials saving, led locals to excavate vaulted caves into the soft but coherent top layers of the volcanic ash, that are widely used as dwellings, stables, wineries, etc.

Their front was enclosed by masonry walls, frequently supporting the veranda of the next house up. The deep caves are typically divided in 2-3 rooms by partitions similar to the front elevations; the front room was for daytime use, with a bedroom and a storage room at the back. These are the best structures to withstand earthquakes, with the additional benefit of acting as free heating and cooling mechanisms due to the large thermal mass of earth.

Topography

Due to the steep ground, a vertical urban layout has been developed: The top of a house is frequently the veranda of the one above -or perhaps a public street. Thus, an unusual 3-dimensional property system has been adopted, requiring close cooperation between neighbours in issues like construction, access, sewage, etc. Needless to say, such a layout requires numerous stairs of many forms & sizes -and of course brave legs & hearts.

Recycling

The major construction difficulty, even today, has been the transport of materials over cliffs and steps with the only available -and best suited- means: donkeys & mules. That explains odd features such as massive rock chunks left on verandas or half-ruined walls merged into later structures, in order to bypass the hard task of taking the rubble away. The excavated walls of caves are sometimes 'adorned' by protruding rocks, left as they were found during construction in order not to alter the stability of the ground or to increase the transportation burden.

3.2 Fire

Cooling

Solar radiation is quite intense in Santorini, especially in summer when clouds disappear for more than two months. Outdoor surfaces, whitewashed just before Easter, reduce the solar load on indoor spaces. At the same time, outdoor areas can become too uncomfortable not only due to solar heat coming from the sky, but also reflected from the sunlit surfaces nearby, especially the light-coloured pavements. Discomfort is intensified by the blinding glare and the heat emitted from the warmed-up mass even after sunset; it is the summer northern winds that may bring relief, provided they are not too strong.

Pergolas and canopies required costly timber; they should also be rigid enough to withstand the forceful winds, thus becoming even more costly. Furthermore, water scarcity and the strong winds prohibit the growth of climbers. For those reasons, solar protection in outdoor spaces was offered only by the shade of adjacent buildings or free-standing walls, the same ones that were used for wind protection too. With such harsh conditions outdoors, it was only the dark indoor spaces that were offering comfort in daytime, thanks to their heavy mass with low radiant temperature.

It is interesting to note that in several cases today a layer of thermal insulation is added on the cave walls, thus cancelling the heat absorption process; even more oddly, more and more air conditioning units are installed due to "demand by visitors".

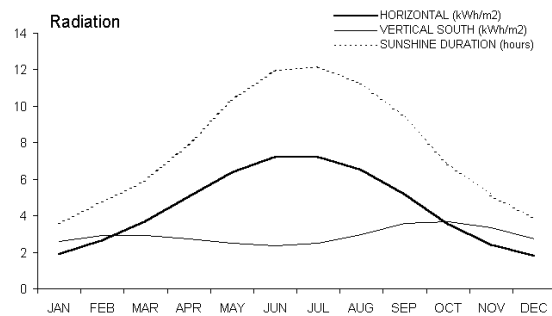

Fig. 8: Santorini is as rich in sunshine as poor in water.

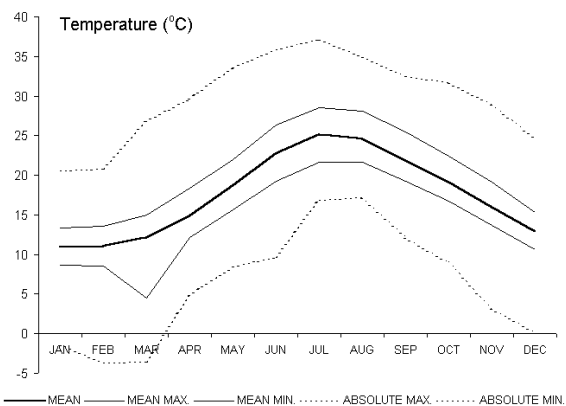

Fig. 9: Mean ambient temperature is above 20°C during 4 months only.

Heating

At the beginning of winter, the reflectivity of the white-washed surfaces is reduced by accumulated dust and the autumn rains. Solar heat is welcome now, but the small windows do not provide much indoors; comfort should be achieved by other means.

Winter is rather chilly in Santorini, humid and windy. The single available fuel for space heating and cooking was bush branches, meticulously picked from the countryside. Small portable stoves were the only substitute to heavy clothes, metabolic heat, or patience, since there are no fireplaces other than the ones in the kitchen.

However, due to the large heat capacity of the earth that dampens down diurnal and seasonal temperature fluctuations, a satisfactory level of thermal comfort can be achieved in the excavated dwellings during most of the winter, reducing the need for extra heating that is required mainly to lessen discomfort caused by humidity.

The small openings minimise heat losses, a vital benefit in the not so distant era when glass was a luxury for the few -if available at all; but at the same time they decrease natural light in the interior, where the only light source was oil lamps and candles.

3.3 Water

Precipitation

Annual rainfall seldom exceeds 370mm in Santorini, and the volcanic earth hardly holds underground water reserves. Consequently plants survive mainly due to air moisture in summer. As said, the meagre vege-

tation offers limited firewood supplies and makes structural timber an exotic luxury.

Snow is another rarity, but humidity is a constant annoying factor, promoting mould growth in the dark, poorly ventilated caves. Additionally, it lessens indoor comfort, especially at the end of winter when radiant temperature of the cave walls is at its lowest.

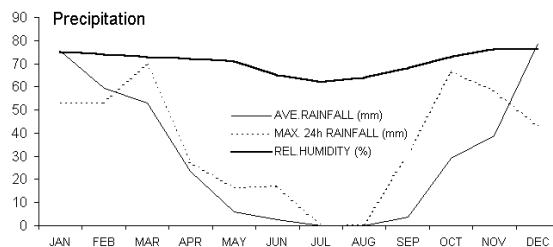

Fig. 10: Relative humidity remains high all year round; rainfall is rare during the summer 5 months.

Domestic water & hygiene

Before the era of bottled water, water tankers, or desalination, the precious liquid was coming only from the sky; hence, rainwater collection was a decisive factor in the overall layout and form of each building – even churches or country houses. The typical dwelling had one or more underground cisterns where rainwater was collected from roofs and terraces via elaborate routes. Stored water was disinfected with a piece of limestone and was carefully withdrawn through a hatch over the cistern. Lime was also used to disinfect the water route that had to remain free of animal droppings.

The washrooms were built away from the main quarters, usually above a small closet containing a collection tank; its contents –mixed with pumice- were periodically transported on donkeys to the fields outside the village as a man-made fertilizer.

A striking change today is the use of old cisterns as septic tanks, and also the addition of numerous swimming pools, again due to “demand by visitors”.

3.4 Air

Wind

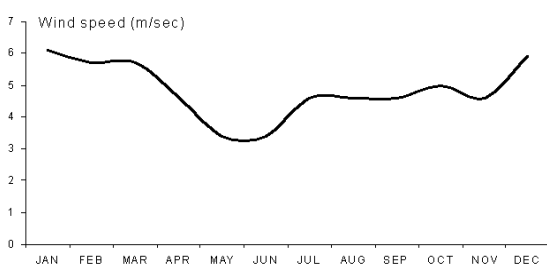

Fig. 11: Santorini is a windy place all year long.

Santorini is totally exposed to the frequent winds that sweep the Aegean Sea, a fact that local plants know too well. It is only the cliffs around Caldera and small valleys that offer some protection, unless they face the incoming air stream when discomfort is intensified by the sand-blast effect caused by turbulence. Wind protection is of prime importance for outdoor living, as shown by many courtyards with raised walls or lowered floors where view has been sacrificed for sheltering.

Ventilation

Ventilation and daylight can be provided into the deep excavated caves only through their façade. The typical clerestory above the door lets the warm air to escape, bringing also daylight to the maximum depth possible. That is supplemented in some cases by vertical ducts through the ground above that admit air and light into the dark and unventilated rooms.

Lack of heating and limited ventilation trigger condensation; this is more so in the excavated vaults that are surrounded by the moisture of the soil. It is easy to imagine the unhealthy living conditions under such circumstances; considering also the chronic water shortages and the co-existence with numerous animals, one should have a smelly rather than idyllic picture of everyday life in the past.

4 Conclusion

If Santorini is to be appreciated, it is not because of its ‘poetic’ forms, or breathtaking vistas: besides vision, living conditions in the past were not very attractive for the other senses or for health. The architecture that we cherish today as ‘picturesque’ is in fact the product of a long struggle for survival in an adverse environment by generations that have managed to squeeze their means out of the available natural resources in a sustainable manner. What should really be honoured is the fact that the locals adapted their notion of comfort and other needs to the local setting, and merged the effects of the four elements into an honest, minimalist architectural idiom, thus offering a brilliant example of vernacular environmental sustainability. Perhaps here we should contemplate the fifth element as the spirit and ingenuity of the locals that have created and sustained life out of the other four.

5 References

Climatic data in this paper is taken from *Greek National Meteorological Service (EMY); measurements 1931-40, 1954-56, 1960-70.*

Comfort zone in Fig. 2 is after *T. A. Markus and E. N. Morris, Buildings, Climate and Energy, Pitman (1980).*



Fig. 12: A dialogue of vaults.

Fig. 13 (next page): Assorted details of Santorini buildings depicting remarks in the text.



	Fire	Water	Air	Earth
<i>layout</i>	• dense fabric for mutual shading		• dense fabric for mutual wind protection	• stepped back due to topography
<i>building types</i>				• excavated • masonry vaults
<i>layout features</i>	• yards for shade	• terraces for rainwater collection	• yards for wind protection	• narrow & deep spaces
<i>materials</i>	• Theran soil for mortar • pumice for insulation	• no water? no timber!	• robustness needed, to withstand wind	• soil easy to dig • large variety of stones • difficult transport
<i>walls</i>	• heat capacity dampens temperature swings		• wind protection • plastered to avoid decay	• earthquake • horizontal vault forces
<i>roofs</i>	• insulated with pumice	• no timber? vaults! • rainwater collection	• heavy to avoid uplift	• covered with pumice
<i>windows</i>	• small size reduces heat transfer	• arched lintels	• shutters behind glazing for wind protection	• small size to avoid wall weakening
<i>forms</i>	• compact to minimise fabric heat flow	• curved structures with compression materials only • rainwater channelling affects geometry	• aerodynamic shapes & details reduce wind effects	• compact to save materials • aseismic rules dictate geometry • embedded rubble & rocks to reduce transport
<i>heating</i>	• minimal direct gain	• no fuel for heating, just for cooking • moisture lessens indoor comfort	• wind may reduce comfort	• thermal mass augments indoor air temperature in early winter
<i>cooling</i>	• high reflectivity reduces solar load • warm mass emits heat	• no timber for shading • no climbers for shading • moisture enhances indoor comfort	• wind may improve comfort • strong winds damage shading devices	• thermal mass absorbs heat improving indoor comfort
<i>ventilation</i>	• clerestories expel warm air	• dampness & mould due to limited ventilation	• clerestories & air ducts enhance air movement	• limited in caves
<i>daylight</i>	• small openings sufficient for summer daylight • clerestories admit daylight more deeply			• limited in caves
<i>watering</i>		• rainwater collection • plants surviving on moisture		• no water reserves in volcanic ground

Table 1: Relation between the four elements and features of Santorini architecture